

Instruction Manual (Supplementary)

Open Type Inverter

TOSVERT **VF-S11**

Thank you for purchasing a Toshiba “Open type TOSVERT VF-S11 series inverter.”
This Manual gives a supplementary explanation of some items referred to in the instruction manual E6581158 included with the product. Please read this manual carefully along with the instruction manual E6581158.

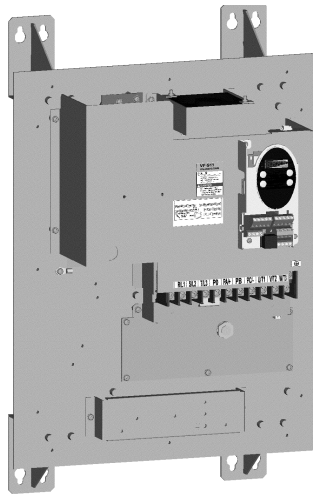

3-phase 500V class 5.5 to 15kW



—To set makers—

Please see to it that this manual is supplied to the inverter's end user, along with the instruction manual E6581158.



■ Safety precautions

Before reading this manual, please read the following instructions in addition to “I. Safety Precautions,” of the instruction manual E6581158.

■ General operation

 Danger	
 Mandatory	<ul style="list-style-type: none"> • The inverter is of an open type, and its high-voltage section, rotary section and hot section are exposed. So be sure to take all necessary measures for safety. Otherwise you could get a shock, get injured or get burned. • The inverter has no means of protecting itself from dust and water drops, so take necessary measures against them. • Do not touch any parts other than the operation panel when the inverter is energized or within 10 minutes after power is turned off. Otherwise you could get a shock, get injured or get burned.

■ Transportation

 Warning	
 Mandatory	<ul style="list-style-type: none"> • When handling the inverter unit, hold it by both the sides firmly.

■ Exterior features

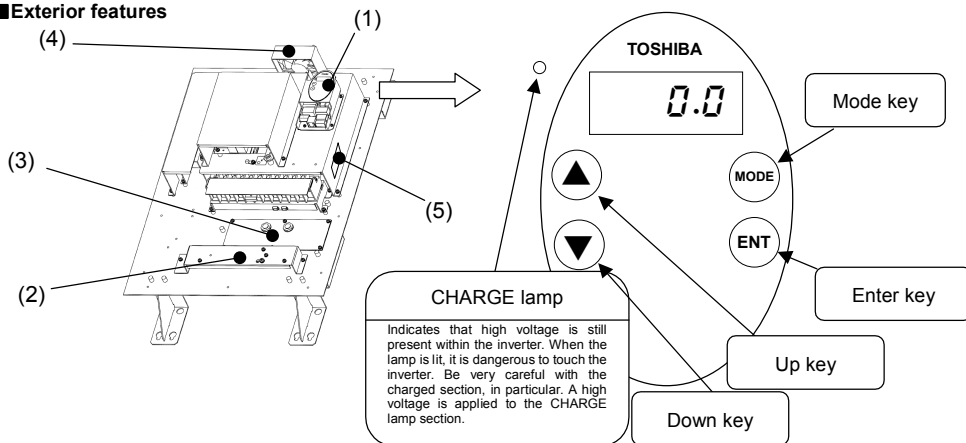

No.	Devices	Remarks
(1)	Operation panel	Equipped with ▲, ▼, MODE and ENT keys used to set parameters, a 7-segment LED and a CHARGE lamp. (The inverter does not have a RUN key, a STOP key and a potentiometer control, which are provided for VF-S11 standard series inverters.)
(2)	EMC plate	The effects of noise can be reduced to some degree by fixing shielded parts of cables.
(3)	Fin cooling fan	Used to cool the cooling fin. Note 1:
(4)	Circuit board cooling fin	Used to cool the circuit boards and other electrical components Note 1:
(5)	Name plate	Label on which the ratings of the inverter unit is printed.

1) Cooling fan

The inverter is equipped with cooling fans. The cooling fan has a useful life of approximately 30,000 hours (2 to 3 years when operated continuously), so it needs to be replaced periodically.

If the cooling fan does not operate normally, the temperatures of the internal electrical components will rise high, and as a result their lives will be shortened. So inspect it periodically.

■ Main circuit and control circuit terminal boards

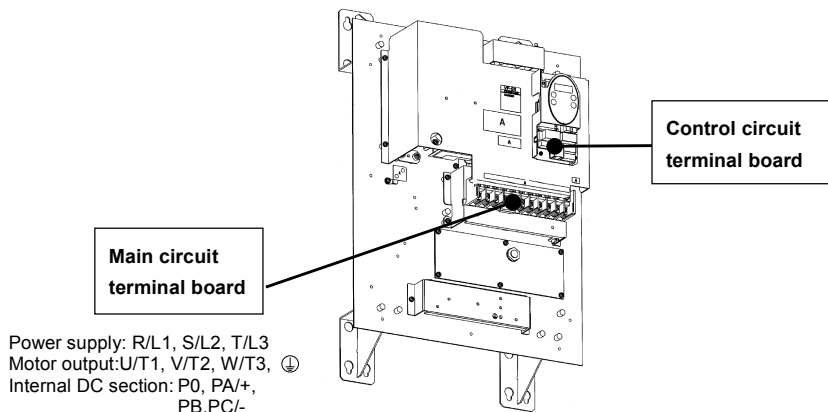

■ Wiring diagram

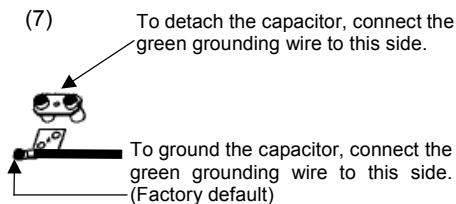
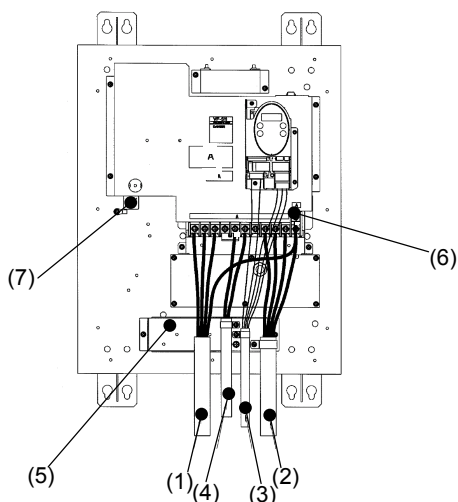

Cautions

- The inverter is shipped from the factory with the main circuit section and the circuit board section exposed. High voltages are applied to some parts in the main circuit section and circuit board section, so read Section 2.1, "Cautions on wiring," of the instruction manual E6581158 carefully before wiring. When connecting cables, take care not to damage the circuit board with a screwdriver or a similar tool. Also, be sure to take necessary safety measures to prevent accidents caused by the high-voltage section, rotary section, hot section, and so on. Otherwise you could get a shock, get injured or get burned.
- For instructions about how to detach the grounding capacitor, refer to 1.3.2 (2), "Grounding capacitor disconnecting switch and taps," of the instruction manual E6581158.

■ Installation environment (Standard installation)

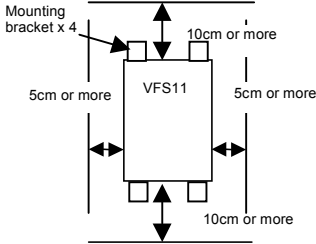

Cautions

- Operate in areas where ambient temperature ranges from -10°C to +40°C.
- Install the inverter in a well-ventilated place and mount it on a flat metal plate in portrait orientation. Install the inverter so that it is not inclined more than $\pm 10^\circ$ from the vertical. Be sure to take necessary safety measures to prevent accidents caused by the high-voltage section, rotary section, hot section, and so on. Otherwise you could get a shock, get injured or get burned.
- Leave a space of 10cm or more on the upper and lower sides of the inverter, and a space of 5cm or more on each side.
- The inverter is equipped with cooling fans. The cooling fan has a useful life of approximately 30,000 hours (2 to 3 years when operated continuously), so it needs to be replaced periodically. If the cooling fan does not operate normally, the temperatures of the internal electrical components will rise high, and as a result their lives will be shortened. So inspect it periodically.

■ Installation environment (When the fan is mounted outside)

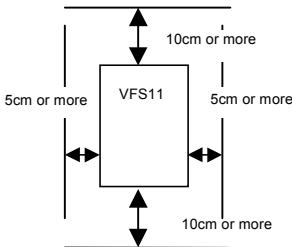

Cautions in mounting the cooling fin outside

- **Insert the inverter unit into the board from the rear and screw the inverter from the front** (5.5 and 7.5kW models: 12 screws. 11 and 15kW models: 14 screws. For board cut dimensions, see page 7.)
- **Leave a working space of at least 1 m to the rear of the board.** The working space is needed for maintenance.
- To protect the inverter unit from dust and water drops, insert the gaskets included with the inverter between the board and inverter unit (part A in the figure). For other parts, be sure to take all necessary measures.

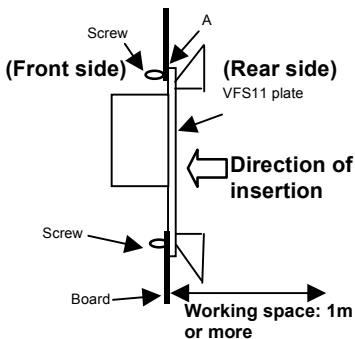

■ Outside dimensions

Voltage class	Applicable Motor (kW)	Inverter type	Outside dimensions (mm)			Installation dimension (mm) *		Drawing
			W	H	D	W1	H1	
3-phase 500V	5.5	VFS11-4055PLU	400	600	243	310	570	Fig. A
	7.5	VFS11-4075PLU						
	11	VFS11-4110PLU	450	700	267	340	670	
	15	VFS11-4150PLU						

* Here are the dimensions for the standard installation.

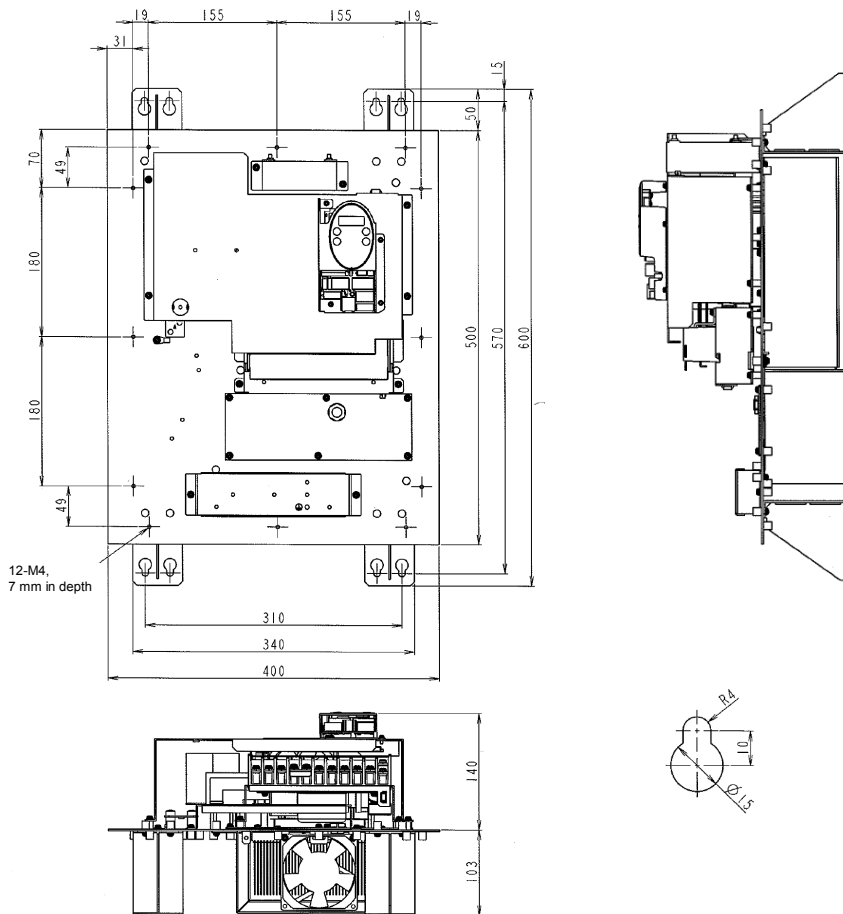

Fig. A

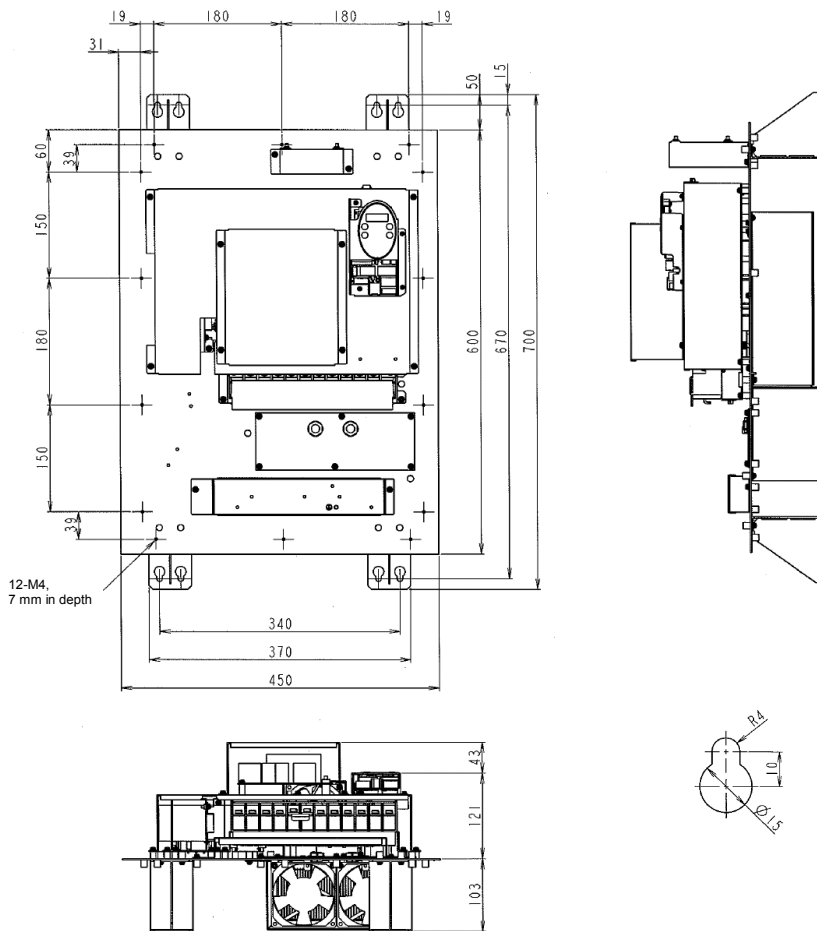

Fig. B

■ Specifications

Item			Specification			
Voltage class			3-phase 500 V			
Applicable motor (kW)			5.5	7.5	11	15
Model	Voltage class	Model number	VFS11-			
	Three-phase 500V class	VFS11-	4055PLU	4075PLU	4110PLU	4150PLU
Rating	Capacity (kVA)	Note 1:	11	13	21	25
	Output current (A)	Note 2:	14.3 (13.0)	17.0 (17.0)	27.7 (25.0)	33(30)
	Output voltage	Note 3:	3-phase 380 to 500V			
Power supply	Overload current rating		150%-1min., 200%-0.5 sec. (50%-reduction value)			
	Voltage-frequency		3-phase 380 to 500V-50/60Hz			
	Allowable fluctuation		Voltage+10%, -15% Note 4.; Frequency±5%			
Protective method			Open type (JEM1030). IP00-Compliant. Cooling fin mountable outside			
Cooling method			Forced air cooling (cooling fan provided to cool the circuit boards)			
Color			Not painted			
Built-in filter			High-attenuation EMI filter			
Environments	Use environments		Indoor type. Altitude: Not more than 1000m. Place free from corrosive and explosive gases			
	Ambient temperature		-10 to +40°C			
	Storage temperature		-25 to +70°C			
	Relative humidity		20 to 93%			
	Vibration		5.9m/s ² or less (10 to 55Hz)			

Note 1: Output capacity at an output voltage of 440V

Note 2: Indicates rated output current setting when the PWM carrier frequency (parameter F300) is 4kHz or less. The values between parentheses refer to output currents at PWM carrier frequencies of over 4kHz. They need to be reduced further at frequencies over 12kHz (If a motor cable over 30m in length is used, it is necessary to reduce them more. This means that the lives of the internal components will be shortened). They need to be reduced more if the supply voltage exceeds 480V. The default setting of the PWM carrier frequency is 12kHz.

Note 3: The maximum output voltage is equal to the input supply voltage.

Note 4: ±10% when the inverter is operated continuously (under a load of 100%).

Note 5: For control specifications, parameters and functions, refer to the instruction manual E6581158.

Note 6: The factory default settings of the following parameters are different from those of the VFS11 standard type.

Title	Function	Standard VF-S11	Open type VF-S11
<i>CND</i>	Command mode selection	1	0
<i>FND</i>	Frequency setting mode selection	0	2

Note 7: The inverter is equipped with cooling fans. The cooling fan has a useful life of approximately 30,000 hours (2 to 3 years when operated continuously), so it needs to be replaced periodically. If the cooling fan does not operate normally, the temperatures of the internal electrical components will rise high, and as a result their lives will be shortened. So inspect it periodically.

■ Dimensional drawing of the board to be cut when mounting the fin outside (for 5.5 and 7.5kW models)

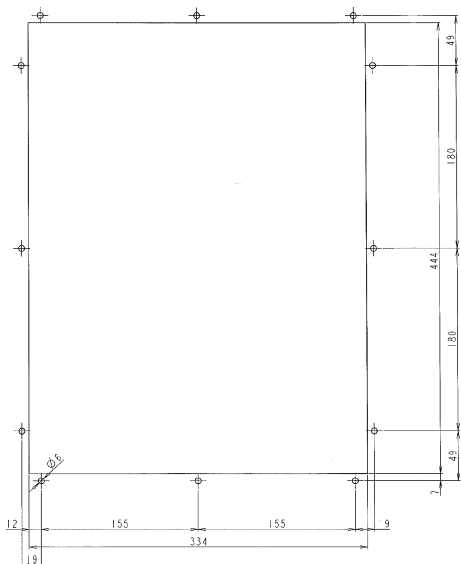

■ Dimensional drawing of the board to be cut when mounting the fin outside (for 11 and 15kW models)

